



Marsha Weyand  
Assessor

# Kittitas County Assessor

205 W 5th Ave Suite 101  
Ellensburg, WA 98926  
Phone: (509)962-7501  
Fax: (509)962-7666



## Property Summary [\(Appraisal Details\)](#)

### Parcel Information

**Parcel Number:** 624935  
**Map Number:** 20-16-26000-0028  
**Situs:** 09370 \SR 970 CLE ELUM  
**Legal:** ACRES 5.09, CD. 6829-1-3-1; SEC.26; TWP.20;  
RGE.16 PTN. SE1/4 S. OF SR97 & N. OF  
TEANAWAY RIVER

### Ownership Information

**Current Owner:** SOMMER, LANCE W ETUX  
**Address:** 8327 20TH AVE NW  
**City, State:** SEATTLE WA  
**Zipcode:** 98117

### Assessment Data

**Tax District:** 44  
**Land Use/DOR Code:** 11  
**Open Space:**  
**Open Space Date:**  
**Senior Exemption:**  
**Deeded Acres:** 5.09  
**Last Revaluation {Reval} for Tax Year:**

### Market Value

**Land:** 110,450  
**Imp:** 143,320  
**Perm Crop:** 0  
**Total:** 253,770

### Taxable Value

**Land:** 110,450  
**Imp:** 143,320  
**Perm Crop:** 0  
**Total:** 253,770

## Sales History

Date	Book & Page	# Parcels	Grantor	Grantee	Price
09-01-1999	8874	1	MACKEY, GERALDINE	SOMMER, LANCE W ETUX	185,000
09-01-1999	41921	1	MACKEY, WILLIAM C. ETUX	MACKEY, GERALDINE	

## Building Permits

Permit No.	Date	Description	Amount
95-06075	06/30/1995	RESOB 1152 S.F..	15,437

## 5 Year Valuation Information

Year	Billed Owner	Land	Impr.	PermCrop Value	Total	Exempt	Taxable	Taxes
2013	SOMMER, LANCE W ETUX	177,080	137,160	0	314,240	0	314,240	<a href="#">View Taxes</a>
2012	SOMMER, LANCE W ETUX	177,080	137,160	0	314,240	0	314,240	<a href="#">View Taxes</a>
2011	SOMMER, LANCE W ETUX	177,080	137,160	0	314,240	0	314,240	<a href="#">View Taxes</a>
2010	SOMMER, LANCE W ETUX	177,080	137,160	0	314,240	0	314,240	<a href="#">View Taxes</a>
2009	SOMMER, LANCE W ETUX	103,680	129,800	0	233,480	0	233,480	<a href="#">View Taxes</a>
2008	SOMMER, LANCE W ETUX	103,680	129,800	0	233,480	0	233,480	<a href="#">View Taxes</a>

### Parcel Comments

**Number**

**Comment**

- 1 SENT OFFICIAL NOTICE OF VALUE, 11/14/2013; 13 FOR 14~
- 2 SENT CHANGE OF VALUE NOTICE, 11/19/2009; 09 FOR 10~
- 3 3)DJC, SR 2/3/05, 2) 4/2001 DG, EST 1 ACRE FW, REMAINDER 100 YR FP FLOODED 1993 UP TO THE PORCH, 1)DG, SR 11/9/00

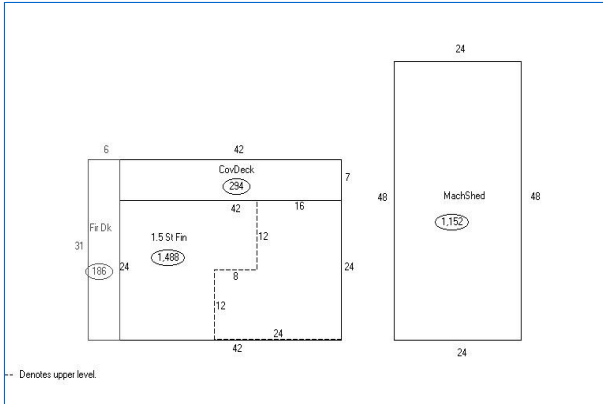

Filedate: 11/25/2013 5:02:00 PM

